

Modern Landings of Efficiency of Air Compressors Piston Ring - Cylinder Tightening

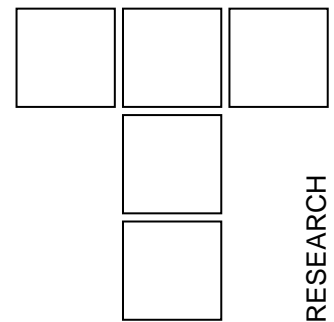

The paper advances a methodology of approaching the tribological processes related to the compressor piston tightening system, based on the tribomodelling by similitude which is an analytical – experimental research method the associated outfits for the experimental research and some results regarding tribological parameters and the influence of these on reliability prediction.

Keywords: piston ring, tightening, reliability prediction

1. INTRODUCTION

The piston ring-cylinder has a large area of spreading in many engineering fields. One of these is the piston air compressors.

This system has a very important role in the case a compressor, to play assuring the energy conversion efficiency.

The efficiency of this assembly is based on tightening assuring for a long time of his life with minimal energy consumption.

In fact, the efficiency and reliability of this tribosystem are defining for the energy consumption characteristic of the compressor.

2. GENERALS

The literature provides data regarding the tribology of this tribosystem and ways for optimizing and durability increasing, but applicability is limited by the narrow experimental domain perspective of the phenomenon that occur.

In this way, the research program developed by scientists from, "Dunarea de Jos" University of Galati, has pursued the following objectives.

Determination of the gas leaking-flow through scaling by theoretical and practical methods as well.

Designing of a physical model, which replicate the tribological processes of the tribosystems.

Elaboration of an prognosis algorithm for the reliability of the system through optimal tribological and thermodynamical data.

In the paper some aspects regarding the research techniques testing rigs and some final results are presented.

Considering the effects of the gas flow loss by the lack of proper sealing of the compressor inside [2] it is convenient to diminish such losses (the ideal case would be to eliminate them but this is impossible).

One of the discontinuity zone of the compressor inside is the piston sealing system where tightness is assured by the tight contact between the sealing elements-piston segments and the two alternative translation moving parts between which there are the piston and the cylinder jacket.

As regards the sliding contact between the piston ring and the cylinder jacket, this is tighter when the radial contact pressure between the two parts is higher. This, however, increases the friction between the two parts resulting in a number of undesired effects such as wear, higher temperature in the area, higher mechanical energy consumption to overcome the friction.

Any approach to the optimization of the piston sealing system should consider: provision of the admissible degree of tightness to obtain some better indices of performance of the thermodynamic process and as low as possible consumptions to overcome friction in the contact zone. As the two objectives have an opposite character they should be investigated separately and from the result interpretations.

FALTICEANU Constantin,
TURCANU Ludmila,
BOLOGA Octavian,
MANEA Mitica,
"DUNAREA DE JOS" UNIVERSITY, GALATI,
ROMANIA

3. THEORETICAL AND EXPERIMENTAL METHODOLOGY

Due to the large number of factor affecting the piston–cylinder assembly [2], it was found convenient to employ the analytical-experimental method of tribo-modeling by similarity.

The relations between the physical parameters on with the tribological processes depend: the contact force N [N], the friction force F_f [N], the relative velocity w [m/s], the shape factor K_f [m⁻¹], the mechanical work consumed for removing the material volume by wear A [J/m³], the ultrasound pulse coefficient α [db/m], the oil flow Q [m³/s], time τ [s], volumetric wear intensity I_v [m³/m], the function:

$$F(N, F_f, w, K_f, A, \alpha, Q, \tau, I_v) = ct. \quad (1)$$

have all been expressed by means of the dimensional analysis by V.A. Voitov [5] as a criterion equation (2):

$$\Pi_I \cdot \Pi_F \cdot \Pi_\tau = ct. \quad (2)$$

where:

Π_I is the invariant of the volumetric use intensity:

$$\Pi_I = \frac{I_v \cdot A^{1/3} \cdot Q^{1/3} \cdot K_f^{2/3} \cdot \alpha^{2/3}}{N^{2/3} \cdot w^{2/3}} \quad (3)$$

Π_F is the invariant of the friction force:

$$\Pi_F = \frac{F_f \cdot A \cdot K_f^{1/3} \cdot \alpha^{1/3}}{N^{1/3} \cdot w^{1/3} \cdot A^{1/3} \cdot Q^{1/3}} \quad (4)$$

Π_τ , is the time invariant:

$$\Pi_\tau = \frac{\tau \cdot N^{2/3} \cdot w^{2/3} \cdot \alpha^{7/3}}{A^{1/3} \cdot Q^{1/3} \cdot K_f^{2/3}} \quad (5)$$

According to the fundamental properties of the similitude and modeling, each invariant should take this value both on the model and on the full scale:

$$\Pi_I(m) = \Pi_I(n); \quad \Pi_F(m) = \Pi_F(n); \quad (6)$$

relations from which the parameters values are determined I_v , F and τ , for the full scale tribosystem depending on the values of the same parameters on the model and the scales of the physical parameters determined:

$$I_{Vn} = I_{Vm} \cdot \frac{k_{K_f}^{2/3} \cdot k_\alpha^{2/3} \cdot k_A^{1/3} \cdot k_Q^{1/3}}{k_N^{2/3} \cdot k_w^{2/3}}$$

$$I_{Vn} = I_{Vm} \cdot \frac{k_{K_f}^{2/3} \cdot k_\alpha^{2/3} \cdot k_A^{1/3} \cdot k_Q^{1/3}}{k_N^{2/3} \cdot k_w^{2/3}} \quad (7)$$

$$\tau_n = \tau_m \cdot \frac{k_N^{2/3} \cdot k_w^{2/3} \cdot k_\alpha^{7/3}}{k_N^{1/3} \cdot k_w^{1/3} \cdot k_A^{1/3} \cdot k_Q^{1/3}}$$

where k_i represents the scale of the physical parameter.

The research team used for the first time a combination of Voitov's relationships for modeling using the computer assisting technique. This because much difference is observed if is not considerable the similarity laws.

For completing and checking the analytical results of mathematical model based on the similarity theory, it is necessary the experimental research results.

4. RESULTS AND DISCUSSIONS

In order to determine the tribological parameters for the piston-cylinder system a tribological research stand was designed by the research team, based on a sliding friction tribomodel. The scheme of this stand is illustrated in Figure.1.

On the bedplate the following are assembled /dismounted: the electrical engine 2, the shaft 3, the upper plate 11. The moving triboelement, the disk 6, receives rotation movement from the engine across a speed reduction gear. The driver when of the assembly being part of the piece where the moving disk is rotating around the shaft 3.

The samples 7 are leaning against the mobile disk; they stand for the fixed tribo-element and they are embedded into the radial grooves in disk 8 which is part of the fixed plate 11 across a subassembly which contains a tensometric couple 9. Rotation around the axis of this subassembly is hindered by two bolts, 12. A controlled force is axially acting upon the above subassembly. The size of the axial force can be varied by varying the length of the lever 10 and the weight suspended at the end of it.

The two rotating and fixed disks are inside a vessel, which is part of the speed reduction gear thus being possible to control the amount of lubricating oil in the friction area. Figure 2 schematically illustrates the tribo-model: 1-the rotating disk (mobile tribo-model); 2 eight samples, 3 fixed disk where the samples are slightly screwed into over circles of

radius r , 5 the tensometric couple, 6 the electronic potentiometer.

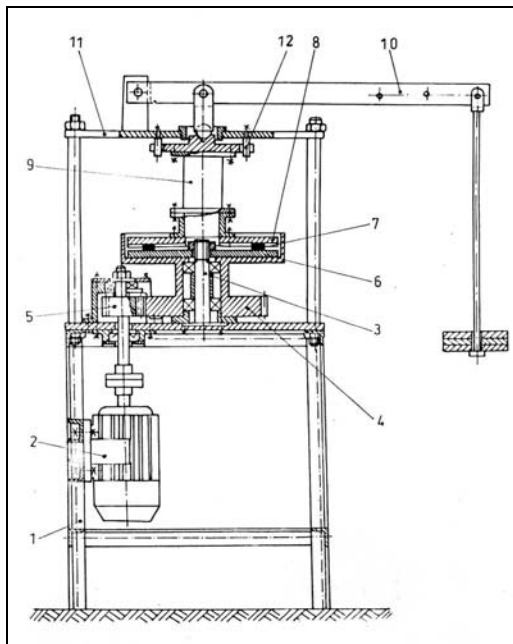

Figure 1. The scheme of stand to determine the tribological parameters for the piston – cylinder system

Experimental researches have been conducted on the above stand to determine the tribological parameters of the piston ring–cylinder tribosystem of the air compressor K 902 [6]. For the experiment purpose the disk of the wheels 1 was made from the same material as the cylinder jacket from the full-scale tribo-system and the samples acting as fixed tribo-elements, were made from the material of the piston ring. The contact surfaces of the two tribo-elements had the same machining quality as in “nature”. Also the same lubricating material was used.

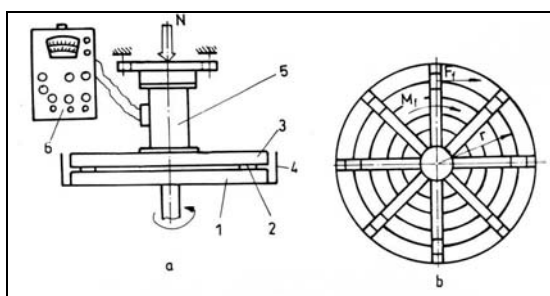

Figure 2. The oversimplified illustration of the tribo-model

In the tribo-model, the sliding contact to axial direction between two cylindrical surfaces is replaced by the sliding contact between flat surfaces and the rotation direction is reversed. With the tribo-system the segment performs the alternate shifting movement to the cylinder at variable sliding speed, while with the tribo-model, the tribo-element simulating the jacket of the cylinder performs the

relative movement of continuing rotation at constant speed against the fixed samples, which represent the piston ring.

In order to make the joint between the outputs resulted by thermodynamic and tribological approaches we will enumerate the thermodynamic determinations and emphasis on the tribological.

The tribological research made on the mathematical and physical models, had the aim the follows:

- determination of the gas flow leakage;
- influence of these leakage on the flow coefficient of the compression stage;
- influence of the gas leakage on the compression mechanic work;
- influence of the gas leakage on the general efficiency of the compressor.

The major aims of the tribological research was to:

- determination of the friction coefficient (μ) and its variation in different work regimes and parameters.
- determination of the wear in various conditions.

The friction coefficient μ calculated with Coulomb relation was determined for a case of limit and dry lubrication, cases well known as worst possible.

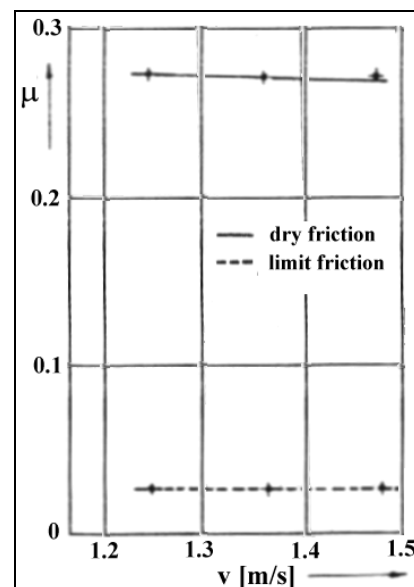

Figure 3.

It is observed that μ is constant with variation of speed within the speed limit for the compressor.

After the limit of 1,5 m/s, a small variation is observed but less important in this case.

The figure 4 present the variation of the wear with speed for bought limit and dry friction.

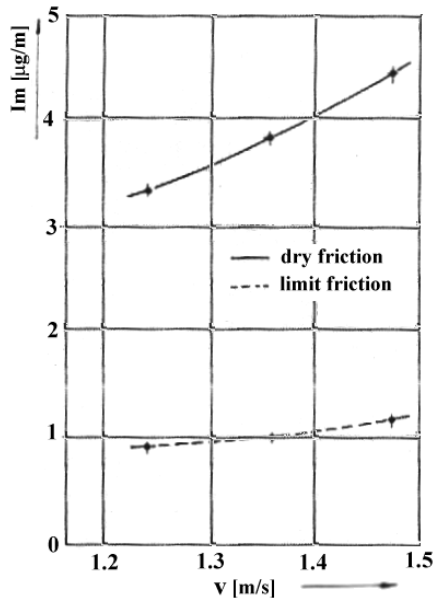

Figure 4.

The variations are positive and linear the biggest pitch being in the case of unlubricated (dry) regime.

The wear intensity by mass has been calculated as it follows:

$$I_m = \frac{\Delta m}{\Delta s} \text{ [kg/km]} \quad (8)$$

where Δs is friction way calculated with relation:

$$\Delta s = u \cdot \Delta \tau \text{ [m]} \quad (9)$$

where u is the speed and $\Delta \tau$ is variation of the time.

With the wear parameters determinate is obtained information regarding reliability of the system, using a prediction parameter of the time between the reparation, the relative leakage flow measuring piston-ring joint.

The length of piston ring joint after the time $\Delta \tau$ is:

$$L_f = a^* + 2\pi\Delta b \cdot 10^{-3} \text{ [mm]} \quad (10)$$

$$a^* = a_0 - \Delta a$$

- distance between the ends of ring, a_0 – this initial distance Δa – variation of a in time $\Delta \tau$.

$f = L_f \cdot \delta_c$ - aria of ring's window, δ_c -

Variation of radial dimension of piston-ring is:

$$\Delta b = V_{hm} \cdot \Delta \tau \quad (11)$$

Distance between the ends of ring is:

$$a^* = a_0 - \Delta a \quad (12)$$

Aria of ring's window is:

$$f = L_f \cdot \delta_c \quad (13)$$

Practical leakage flow trough piston sealing is:

$$m_p = \frac{1}{az+b} \quad (14)$$

Theoretical leakage-flow trough piston sealing is:

$$m_t = \frac{p_a \cdot v_c \cdot n}{R \cdot T_a \cdot 60} \text{ [kg/s]} \quad (15)$$

Was choused the qualitative indicator of piston sealing system function, the relative leakage:

$$v_p = \frac{m_p}{m_t} \quad (16)$$

In these relations δ_c is clearance of piston, a and b are the experimental coefficients depending by area of ring's window, z is the order number of the ring.

The figure 5 presents the variations of relative leakage-flow in time for various compression levels.

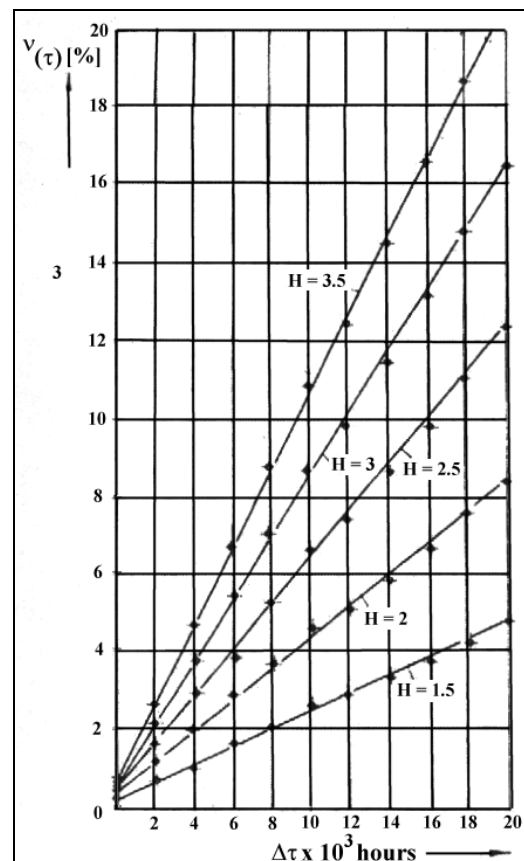

Figure 5.

The diagram $v(\tau)$ can be used in designing of compressors for the reliability forecasting.

5. CONCLUSIONS

- the value of friction coefficient after measurements and statistic interpretation was established to 0,035 and did not have visible variations with speed increasing in limit friction;
- friction coefficient has drastically variations at change of lubricating regime. It can arrive at a value of 0,27 - 0,3.
- wear intensity presents an easy increase with increasing at speed. This rate of increasing is the biggest at dry friction regime;
- it was elaborated a methodology by study prediction time between the reparation, using the ratio of variation of ring window;
- the variation of "relative leakage" in time can be used in designing of compressors and in maintenance field.

REFERENCES

- [1.] Falticeanu C.: Elemente de tribologie, Editura Fundatiei Universitatea "Dunarea de Jos", Galati, 2000.
- [2.] Turcanu L.: Contributions about the Study of Piston Compressors Tightening, Ph. D. These, Galati, 1999.
- [3.] Turcanu L., Falticeanu C.: Incercari experimentale privind uzura in sistemul de etansare al pistonului de compresoare, Conferinta nationala a Termotehnicienilor, Craiova, 1999.
- [4.] Turcanu L., Falticeanu C.: Methodology and Systems for Investigating the TriboSystem Piston Ring-Cylinder from Compressors Machine, Analele Universitatii "Dunarea de Jos", Fasc. Tribology, 2000.
- [5.] Voitov V., Isakov D.: Modelirovanie geanichinogo trenia v tribosistemah, Rev. Trenie i Iznosti, 3/1996.
- [6.] Voitov V. A., Venikov G.: Teoria podobia i modelirovania, Vissaia sola Moskva, 1984.
- [7.] Falticeanu C., Turcanu Ludmila, Falticeanu C. L.: Some Researches Regarding the Behaviour of Piston Ring-Cylinder TriboSystem from the Piston Compressor, Balkantrib, Turkey, 2002.