



Increasing the Efficiency of Wind Turbines

Jamaladdin N. Aslanov^{a,*} , Zenfira S. Huseynli^a , Kamran C. Cafarov^a 

^aAzerbaijan State Oil and Industry University, 20 Azadlig Avenue, Baku, Azerbaijan.

Keywords:

Wind energy
Improved wind turbines
Main shaft
Rotational speed
Bearing load balancing

* Corresponding author:

Jamaladdin N. Aslanov
E-mail:
camaladdin.aslanov@asoiu.edu.az

Received: 15 May 2025
Revised: 3 July 2025
Accepted: 10 August 2025



ABSTRACT

The research work is devoted to the improvement of wind turbines.

Wind turbines do not work when the minimum wind speed is 5 m/s. However, they ensure their operability when the wind speed exceeds 6 m/s. The creation of shock-resistant wind turbines that can operate in low wind conditions and are easy to install is currently relevant.

The article presents improved wind turbines that can operate at low wind speeds by increasing the friction force acting on the turbine blades based on the Bernoulli principle.

The study proposes an optimal patented wind turbine that works by increasing the wind speed due to the friction force acting on the turbine blades and has the ability to be conveniently installed in residential buildings. Also, a power analysis of the turbine was carried out based on Bernoulli's law and the pressure resistance of the turbine was checked using modern programs.

© 2025 Published by Faculty of Engineering

1. INTRODUCTION

Wind is a renewable energy source and generally has a lower environmental impact than many other energy alternatives. Wind turbines minimize the release of toxic substances into the environment, thereby causing minimal harm to human health [1].

Wind energy does not produce waste and does not pollute water - an extremely important factor due to water scarcity. Unlike geothermal and nuclear power plants, wind energy has a significantly lower water consumption, conserving hydrological resources and eliminating the need for cooling water. In addition, wind turbines have the ability to

reduce dependence on fossil fuel-generated electricity, thereby reducing overall air pollution and carbon dioxide emissions [2].

Today, there is a great need for alternative energy sources in world practice. Wind turbines are one of the alternative energy sources with a very low negative impact on the environment. Currently, these turbines are widely used in windy areas such as coastal areas and mountain slopes. The application of wind turbines in areas with low wind speed remains a pressing problem.

For these reasons, generating electricity from wind energy and using it efficiently contributes to sustainable development. However, modern wind

turbines also have some disadvantages. Their installation can have a detrimental impact on both the environment and the landscape, requiring extensive construction work and the clustering of turbine clusters in close proximity. In addition, there is the potential for environmental damage; although rare, fires and oil leaks have occurred at some wind turbines. In addition, the noise generated by the turbine blades rotating in the wind can have a negative impact on the health of people living near these installations. Some wind turbines are one of the most effective causes of bird mortality, which can contribute to the reduction of their populations [3].

Wind turbines become less efficient when the wind speed is less than 5 m/s. There is currently a great need for wind turbines that can operate at low wind speeds and can be placed on top of buildings. Therefore, the aim of the research work is to develop a new wind turbine that can operate at low wind speeds and can be placed on top of buildings [4].

It is difficult to imagine air as a liquid because it is invisible. Unlike a liquid, air moves much faster and covers its surroundings. "Wind Energy" is the process of converting this air flow into kinetic energy.

The working principle of the wind turbine is as follows. The wind flow acting on the propeller and forwarding its kinetic energy rotates it, which sequentially rotates the main shaft of the installation. The shaft connected with Gear Box which increases the speed between the shaft and the propeller this help us to provide a faster rotation for the equipment [5].

We have two primary shafts: shaft with low speed and shaft with high speed. The shaft with low speed is positioned between rotor hub and gearbox, responsible for transmitting rotational motion of the blades to the gearbox. On the other hand, shaft with high speed is situated between gearbox and generator, facilitating transmission of rotational motion from the gearbox to the generator.

The generator is a component that converts mechanical rotation into electricity [6]. Wind turbines include also the main parts like: nacelle turning mechanism, tower, power lines, control and power electrical systems, rotor hub, blades, main bearing and etc (Fig. 1).

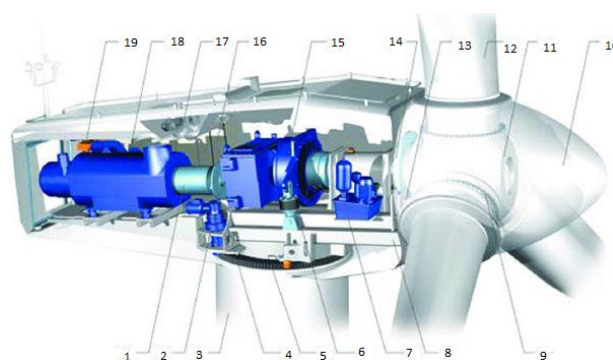

Fig. 1. Main components of wind turbine: 1-Transmission high speed shaft, 2-Yaw gears, 3-Tower, 4-Brake, 5-Yaw ring, 6-Shock absorbers, 7-Hydraulic unit, 8-Bed frame, 9-Blade bearing, 10-Hub cover, 11-Hub, 12-Blade, 13-Rotor lock system, 14-Main shaft with two bearings, 15-Gearbox, 16-Top control unit, 17-Cooling system, 18-Generator, 19-Service crane.

The brake unit of wind turbines shown in Fig. 1 is constantly under mechanical force and operates under load. Since the brake teeth are subject to breakage and wear, the calculation of the load of these parts and the selection of materials must be carried out very carefully.

In modern world wind turbines have two main types: those rotating along a vertical axis and those rotating around a horizontal axis. They can have up to 40% efficiency and be either slow-moving multi-blade designs or high-speed single-blade designs [7].

Advantages:

1. Environmental Cleanliness: Wind turbines do not produce environmental pollution.
2. Use of Renewable Energy: They harness an infinite energy source without associated costs.
3. Minimal Energy Transmission Losses: Wind turbines can be installed close to consumers or in remote areas, reducing energy transmission losses.

Disadvantages:

1. Power Variability: Wind turbine productivity is directly linked to wind strength, resulting in fluctuations over time.
2. Noise: Recent studies suggest that noise pollution from wind turbines is insignificant, typically blending with ambient noise levels at distances of 30-40 meters.

3. Impact on Birds: New modified wind turbines are completely safe and harmless for birds and etch.

Recently, modified wind turbines can generate minimum 3-5 m/s and maximum 25 m/s wind speed which is perfect. The only problem is the low efficiency of the turbines which can be modified.

A brief overview of the scientific direction of the project and the problem a global problem in the wind energy industry is the mechanical failure of the main bearings of wind turbines. The reason for this is the loss of profitability with an increase in the power of installations.

With an increase in the power of wind turbines, unfortunately, the durability of the main bearing and the entire installation decreases, respectively, since uneven torques and dynamic loads act on the main bearing and shaft, it has been brought on by the wind flow's unequal effect [8].

Wind turbine gearbox and bearings.

The gearbox is one of the most expensive and heaviest parts of wind turbines, as they can account for 13 to 20 percent of the total cost of the installation and weigh up to 30 tons. Approximately 1,200 incidents of gearbox and bearing failures are reported each year, translating to approximately one failure per 45 turbines (USA 2020) [9].

Research shows that eliminating mechanical failures of wind turbines is one of the main conditions. One of the goals of the research is to clarify the causes of mechanical failures and put forward proposals for their prevention.

The gearbox in wind turbines consists of several planetary and stepped gears, drive and driven shafts, and of course bearings. This mechanism facilitates the transmission of rotational motion from the wind-spun turbine blades to the electricity generator, converting the wind's mechanical energy into electrical energy. For 21st century, bearings are one of the most important mechanical and tribological parts of machines and mechanisms used in a very wide range, including the automotive, aerospace, energy, oil and gas industries, construction and etc [10].

The transmissions in wind turbines are composed of and made from many different types of bearings.

Gearboxes and bearings in the wind power industry are usually calculated and certified for service for at least 15-20 years, unfortunately a very small percentage are operated without flaws for such a long period. Consequently, most manufacturers of bearings are showing great and special interest in bearings used in wind turbines, striving to develop the most rigid, reliable, and durable bearings [11].

In case of incidents and breakdowns in wind turbine gearboxes, downtime can be extended, depending on the availability of spare parts, from two days to several months. Which is a very big waste of energy and resources (Fig. 2).

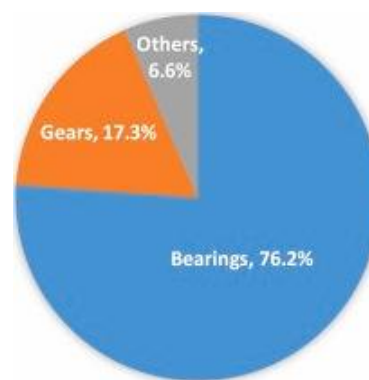

Fig. 2. Variation of failures in wind turbine gearboxes.

The primary failing components in wind turbine gearboxes are as follows:

- Bearings: 76.2%
- Gears: 17.3%.

The main causes of problems and breakdowns in gearboxes can include the following situations:

- Dirty oil or water mixtures.
- External conditions such as: braking, wind level, gusts, power factor;
- Low maintenance.
- Transient loads leading to rapid accelerations and reversals of the load zone.
- High edge stresses resulting from improper installation or adjustment of the bearing, as well as uneven load distribution.

Other parameters that play an important role in wind energy must also be considered: power, efficiency, performance, slip, ability to withstand environmental loads, efficient cooling at maximum and partial load. In case of breakdowns and incidents in gearboxes, sometimes the only way out is to completely replace the gearbox [12].

In the research work, we want to consider the loads on the main power carrier of the wind turbine. Increasing the efficiency and reliability of the main bearing of the turbine and the gearbox assembly is one of the important issues on the agenda. This problem finds its constructive solution in the new design of the wind turbines we propose.

The aim of the study: to develop wind turbines that can operate at low wind speeds, are resistant to mechanical forces and can be placed on various objects [13].

2. TURIBI'S RESEARCH AND METHOD SELECTION

By mechanically increasing the natural wind speed inside the wind turbine, the turbine's useful efficiency is increased, the equipment's efficiency is ensured at a lower speed and, as a result, more kilowatts of energy are obtained in a small area.

The design of HOKT wind turbines by us has been improved based on the Bernoulli law, the working mechanism. The improved wind turbine consists of a base, powerful contactors and control circuits, a power cabinet, a tower, a ladder, a rotary mechanism, an electric generator, a wind direction and speed monitoring system, anemometer, blades, a blade guide and a top cover, and its structure consists of five steps with a rectangular cross-section from a large diagonal step to a small diagonal step, a wind catcher located at the entrance and between each step, two curtains in the first step, one curtain in the second, third and fourth steps, and the last step is a gap with access to the atmosphere.

The wind turbine consists of a base, powerful contactors and control circuits, a power cabinet, a tower, a ladder, a rotary mechanism, an electric generator, a wind direction and speed monitoring system, anemometer, blades, a blade guider and a top cover. A stepped wind catcher consisting of five stages, from a large diameter stage to a small diameter stage, is added to its structure, and a blade is placed in the first stage, a wind deflector between the first and second stages, a blade in the second stage, a blade in the third stage, a blade in the fourth stage, and the last stage is a space with an outlet to the atmosphere. Since the design of the wind catcher at the entrance of the wind

turbine is built according to Bernoulli's law, the wind speed will increase by the calculated parameter. As a result, since the wind speed with the same rotational force of two blades is obtained at the same time, two blades are installed in the first stage. Starting from the second stage, each stage of the blades must have one blade and be located at the entrance. After the wind spends a certain part of its kinetic energy at the inlet to rotate the impeller, it will be directed through the internal wind catcher and move from a large diameter to a small diameter, increasing its speed. The accelerated wind will move to a new stage and rotate the next impeller. The last stage has a gap with an exit to the atmosphere to ensure the free flow of wind. The number of stages depends on the wind speed and the large dimensions of the structure. The optimal size is a 5-stage structure. The first figure shows the general appearance of the wind turbine, and the second figure shows the working unit.

The structure of the improved wind turbines consists of a base 1, a power cabinet 2 including powerful contactors and control circuits installed on it, a tower 3, ladders 4 and a rotary mechanism 5, an electric generator 6 located at the top of the tower, a wind direction 7, a speed monitoring system (anemometer) 8, blades 9, and a wind deflector 10 for the blades, an upper cover 11 covering the mentioned details, a wind catcher 12 located at the bottom of the cover, a support 13 holding the tower, and a body 14 containing the details (Fig. 3).

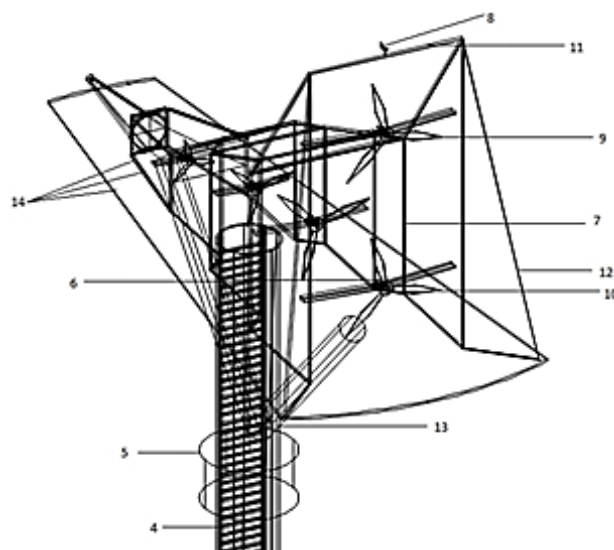

Fig. 3. Plan of the improved wind turbine

A new wind turbine has been proposed and patented, which works by increasing the wind speed based on the friction force acting on the turbine blades [14]. The proposed wind turbine consists of 5 rectangular sections. The diagonal of these sections decreases in the direction of decreasing passage. The calculation of the increase in wind speed is determined by Bernoulli's law.

The study conducted a force analysis of the turbine based on Bernoulli's law. In addition, an experiment was conducted to test the impact resistance of the wind turbine body using a laboratory stand. Pressure calculations (Fig. 4) and (Fig. 5) were performed in SolidWorks software based on the driving force of the wind.

Wind Energy Density is a quantitative measure of the amount of wind energy available at any location. It is the average annual energy output per square meter of the swept area of the turbine. Wind energy density was calculated depending on the height of the wind turbine above the ground. The parameters of wind speed and air density were taken into account in the calculation of wind energy density. The calculation of turbine efficiency was determined in accordance with the laws of current mechanics [15,16].

Wind turbines are rated by classes. Wind turbines are classified into classes I-III according to the wind speed at which they are designed to operate. Classes A-C in these classes represent classes that take into account the intensity of wind turbulence. The new wind turbine we proposed has been added to the classification table (Table 1).

2.1. Analysis of innovation

The creation of the new structure is based on the tribological movement of the wind, based on Bernoulli's law. By increasing the friction force between the wind blades, the rotation of the turbine blade will be ensured at low wind speeds. This is the main principle we need for the structure to work. To increase the friction force between the wind and the blades, it is necessary to change the movement of the wind from a large-diameter wind catcher to a small-diameter wind catcher. According to Bernoulli's law, this movement will increase the wind pressure. This increase will increase the friction force generated on the blades.

The wind speed captured by the catcher inside the installation is raised by the computed value with the aid of a wind catcher. This results in equal wind speeds at the installation's top and bottom, eliminating resonance vibrations and enabling the equal speed rotation of two vertically positioned wind turbines connected in series with a horizontal axis of rotation. At the first stage of this installation, as noted, 2 wind blades will be installed.

The wind will eventually reach the second stage, regenerate its kinetic energy, and decrease from a bigger diameter to a small one. Bernoulli's law will also cause the wind speed inside the installation to grow, reaching the end of the second stage, spins a small-diameter turbine, thereby losing part of the kinetic energy converting it into electrical energy. After the wind passes through the second stage, the wind moves turbulently and with low energy. But in a special narrow passage, the turbulent regime is balanced by turning into a laminar one, and then, just like in the second stage, passing from a larger diameter to a small one increases the speed, thereby increasing the kinetic energy.

Having restored the kinetic energy, the wind spins the last turbines on the third and fourth stages in succession and tends to leave the installation after passing through the fifth, also regenerating and stabilizing.

The fifth stage is completely hollow and has nothing; thus, a pressure difference is achieved inside and outside the installation and the wind tends to leave the installation and is thrown back into the atmosphere, dragging the wind behind it. Using this installation, according to the results of experiments and calculations, a power of 2 times more than in traditional wind turbines is achieved.

The shows that due to the different heights of the blades in dynamics, they are affected by different wind speeds, which leads to an uneven distribution of the load on the shaft and the occurrence of a torque with a radial load. Wind turbines are divided into classes according to wind speeds in Table 1. The proposed improved wind turbine will be in the Class 1 A category.

The improved wind turbine we propose corresponds to Level 1 (Table 1) [16,17].

Table 1. Classification table.

Class	Average Wind Speed (m/s)	Turbulence	Note
I.A	5	10%	Proposed
I.A.	10	16%	Available
I.B.	10	14%	Available
IC	10	12%	Available
IIA	8.5	16%	Available
IIB	8.5	14%	Available
IIC	8.5	12%	Available
IIIA	7.5	16%	Available
IIIB	7.5	14%	Available
IIIC	7.5	12%	Available

Fig. 4 of position C shows the diagram of the resulting loads on the main bearing. In the same diagram, position D shows the cracks arising from these loads on the outer race and the bearing housing.

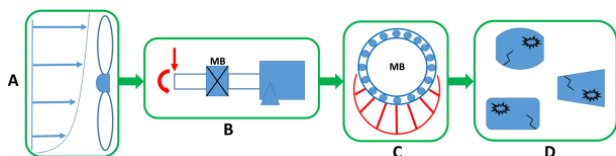

Fig. 4. Load diagram of bearing

A patent has been obtained for a new wind turbine that eliminates the above-mentioned shortcomings (Fig. 4) and (Fig 5).The proposed improved wind turbine is shock-resistant, capable of operating at low wind speeds and can be installed on objects.

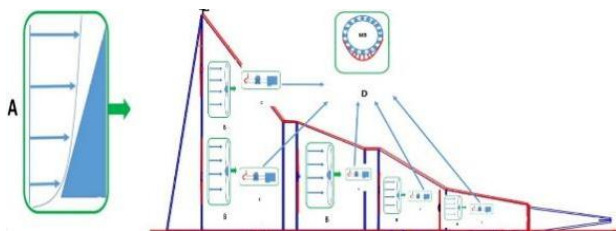

Fig. 5. Bearing location on the main constructive.

The shape of it strunk was calculated and designed based on Bernoulli's law.

The development of a shock-resistant wind turbine that can operate at low wind speeds and can be installed on objects.

In (Fig. 6), at position A, you can see a plot of wind speeds, it is noticeable that the higher the stronger the wind. Considering this factor, in the design we propose, there is a wind catcher

that is made in the form of a right-angled triangle, which contributes to equalizing the lower and upper winds. According to Bernoulli's principle, the fluid flow rate increases. In this scenario, likening the air flow to a liquid, as previously mentioned, helps illustrate the phenomenon.

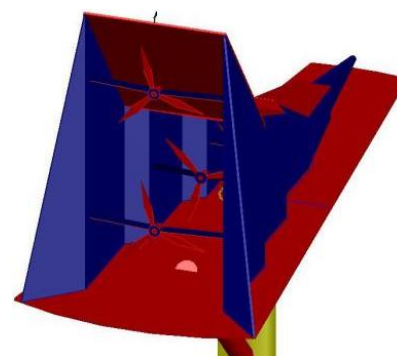

Fig. 6. Improved wind turbine.

After passing the wind through the wind catcher, and passing through the first 2 turbines, which are parallel in the vertical plane, it transfers some kinetic energy to the turbine, thereby losing part of its energy to spin the turbine. In its further movement, the wind enters the corridor, where, under the influence of some equalizers, it passes from the turbulent mode to the laminar one and, at the next stage, it compresses smoothly, moving from a larger to a small cross section. This achieves an increase in wind speed, thereby increasing its kinetic energy. And the wind spins the turbine located at this stage. This process is repeated 3 times each time decreasing the radius of the turbine but regenerating and increasing the wind speed. In the last section there is nothing that allows the extraction of the wind by obtaining a pressure difference inside the installation and outside it. In this way, we gain more than 2 times the efficiency in the generated power.

Based on 274 hours of computer simulation, it was found that, by increasing the speed of the wind flow in the lower part and equalizing it to the upper one, we obtain a flow with a uniform speed both in the lower and in the upper part of the installation. Thus, we get an even distribution of loads and torques on the main shaft and bearing, as well as increasing the wind speed, we increase general power of turbine and the initial wind speed at which the installation begins to generate electricity.

This innovation is a wind turbine that can extract more electrical energy from mechanical wind energy than traditional wind turbines can. This is achieved through a novel multi-stage static structure, which operates on principles derived from Bernoulli's law. Wind turbine power is dependent on speed of the wind (v), zone of swept ($S = \pi r^2$), wind energy coefficient use ($\eta = 0.6$). The formula expressing this relationship is $N = \rho S v^3 / 2$. Main formulas, which are commonly used to calculate the power of a wind turbine. However, the more simplified and frequently employed formula is as follows:

$$N = \eta \cdot \pi \cdot r^2 \cdot v \tag{1}$$

where:

- v - represents the speed of the wind,
- η - denotes the wind energy coefficient utilization,
- r - signifies the blade radius.

Achieving parameters and their value closely reflective of reality, it's essential to consider the following losses:

1. Gearbox's factor of the loss (0,6).
2. The transmission's factor of the loss (0,8).
3. Generator's factor of efficiency (0,8) when employing newly enhanced design.
4. Aerodynamic friction loss's coefficient (0,8).

With radii ranging from 1 to 15 meters and an average annual speed of the wind 5 m/s, conventional horizontally axial wind turbines with circular rotation were first calculated using the aforementioned method for comparison's sake.

The wind turbine's incoming wind speed is increased by the computed value due to the wind trap. As a result, a wind force strong enough to propel two wind turbines at the same time is reached, starting the first stage of the turbines' rotation. In the first stage, wind entering the device transitions from a larger to a smaller diameter, in line with Bernoulli's principle, resulting in an increase in wind speed, thereby consequently powering the turbine on the next part. The wind then continues the same pattern in subsequent stages as it expands most of its kinetic energy leaving the second stage and moving on to the third, and so on. Law of the Bernoulli's states that this acceleration increases

its speed, which restores its kinetic energy and turns turbines that are placed on later stages. Ultimately, the fifth stage allows the wind to be released into the atmosphere.

The power of the wind turbines we are offering will grow by 2-3 times compared to traditional constructions, according to theoretical estimations.

Since wind thrust forces cause stresses in turbine blades, we will use the following formula to calculate the stress in the blades.

These formulas can be used for defining the stress in blades not only for wind turbine but also the tidal turbine.

$$F_x = C_x \frac{1}{2} \rho S V_{fluid}^2 \tag{2}$$

where,

- ρ - the fluid density,
- V_{fluid} the fluid velocity,
- C_x - thrust force coefficient,
- S - distance.

This thrust force's strength is equivalent to

$$P_x = V F_x \tag{3}$$

$$V = a V_{fluid} \tag{4}$$

and

$$\frac{1}{2} \leq a \leq 1 \tag{5}$$

$$P_x = a C_x \frac{1}{2} \rho S V_{fluid}^3 \tag{6}$$

V representing the fluid velocity at the turbine's location.

The total power is equal to

$$P_T = P + P_x = (C_p + a C_x) \frac{1}{2} \rho S V_{fluid}^3 \tag{7}$$

with

$$(C_p + a C_x) \leq 1 \tag{8}$$

and

$$C_p = 4a^2 (1 - a) \tag{9}$$

$$C_x = \frac{1}{a}(1 - C_p) \tag{10}$$

For more energy to be created, the power P needs to be greater than the thrust power F_x.

$$P \geq P_x \tag{11}$$

$$C_p \geq aC_x \tag{12}$$

This is how the previous equation is solved:

$$C_p = aC_x \tag{13}$$

$$-\frac{1}{4}\left[4a^2(1-a) - \frac{1}{2}\right] = 0 \tag{14}$$

$$-\frac{1}{4}\left[4a^2(1-a) - \frac{1}{2}\right] = \left(x - \frac{1}{2}\right)(x - a_2)(x - a_3) \tag{15}$$

The above expressions allow us to calculate the stress on the blades of a wind turbine and the power of the turbine. Calculations show that the power generated by the new design increases by about 2 times compared to traditional designs.

Bernoulli's principle is expressed as follows.

$$\frac{\rho v^2}{2} + \rho gh + p = const \tag{16}$$

According to expression 16, as the wind passes through each step, the height of the step decreases by half, therefore its speed will increase by half. As a result, the friction force will also increase due to the force F acting on the turbine blades.

Due to the increase in the friction force acting on the blades, a useful torque is obtained. This will increase the small speed of the wind and ensure the operation of the turbine.

Our proposed advanced wind turbines are different from existing wind turbines. Thus, the wind enters the body of the improved turbine and rotates its blades. For this, we simulated and monitored the pressure created by the wind inside the body.

The graph above shows the simulation analysis of the force effect of the structure (Fig. 7).

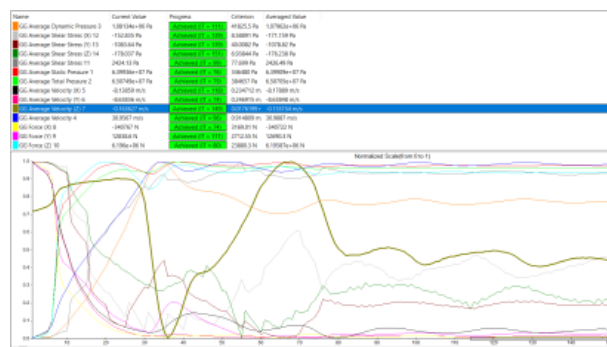

Fig. 7. Simulation analysis of the force effect of the structure

The processing of the results shows that when the proposed wind turbine operates at a wind speed of 5 m/s, its body is resistant to the operating pressure.

2. CONCLUSION

1. A wind turbine that can operate at low wind speeds by increasing the wind friction force has been proposed.
2. The proposed wind turbine is a new wind turbine that combines the features of various existing designs and is resistant to mechanical shocks. Simulations show that the proposed wind turbine reduces the load on the main bearing by up to two times due to the wind catcher, and as a result, extends its service life, as well as the life of the entire transmission system.
3. The proposed wind turbine starts operating at a wind speed of 5 m/s, which is half the starting speed of existing turbines.

REFERENCES

- [1] S. Rajamohan et al., "Approaches in performance and structural analysis of wind turbines – A review," *Sustainable Energy Technologies and Assessments*, vol. 53, p. 102570, Jul. 2022, doi: [10.1016/j.seta.2022.102570](https://doi.org/10.1016/j.seta.2022.102570).
- [2] M. Popescu and T. Flåtten, "A study of blockage effects at the wind turbine and wind farm scales," *Energies*, vol. 14, no. 19, p. 6124, Sep. 2021, doi: [10.3390/en14196124](https://doi.org/10.3390/en14196124).
- [3] T. Kara and A. D. Şahin, "Implications of climate change on wind energy potential," *Sustainability*, vol. 15, no. 20, p. 14822, Oct. 2023, doi: [10.3390/su152014822](https://doi.org/10.3390/su152014822).

- [4] J. Wang, F. Golnary, S. Li, A. U. Weerasuriya, and K. T. Tse, "A review on power control of wind turbines with the perspective of dynamic load mitigation," *Ocean Engineering*, vol. 311, p. 118806, Aug. 2024, doi: [10.1016/j.oceaneng.2024.118806](https://doi.org/10.1016/j.oceaneng.2024.118806).
- [5] T. Li, Q. Yang, X. Zhang, and Y. Ma, "Efficient fatigue damage estimation of offshore wind turbine foundation under wind-wave actions," *Journal of Constructional Steel Research*, vol. 221, p. 108903, Jul. 2024, doi: [10.1016/j.jcsr.2024.108903](https://doi.org/10.1016/j.jcsr.2024.108903).
- [6] E. Sorge, C. Riascos, N. Caterino, C. Demartino, and C. T. Georgakis, "Optimal design of a hinge-spring-friction device for enhancing wind induced structural response of onshore wind turbines," *Engineering Structures*, vol. 314, p. 118305, Jun. 2024, doi: [10.1016/j.engstruct.2024.118305](https://doi.org/10.1016/j.engstruct.2024.118305).
- [7] M. Babanli, R. Mekhtiyev, N. Gurbanov, J. Aslanov, and Yu. Tanriverdiev, "Cracks in hybrid fiber metal laminated nanocomposites under uniaxial tension," *Journal of Applied Mechanics and Technical Physics*, vol. 63, no. 5, pp. 876–883, Nov. 2022, doi: [10.1134/s0021894422050170](https://doi.org/10.1134/s0021894422050170).
- [8] K. S. Mammadov and J. N. Aslanov, "Frictional wear of improved valve hermetic elements caused by heat transfer," *Journal Tribology*, vol. 35, pp. 134–149, 2022.
- [9] H. Peng, S. Li, L. Shangguan, Y. Fan, and H. Zhang, "Analysis of wind turbine equipment failure and intelligent operation and maintenance research," *Sustainability*, vol. 15, no. 10, p. 8333, May 2023, doi: [10.3390/su15108333](https://doi.org/10.3390/su15108333).
- [10] Y. Aafif, A. Chelbi, L. Mifdal, S. Dellagi, and I. Majdoulne, "Optimal preventive maintenance strategies for a wind turbine gearbox," *Energy Reports*, vol. 8, pp. 803–814, Aug. 2022, doi: [10.1016/j.egy.2022.07.084](https://doi.org/10.1016/j.egy.2022.07.084).
- [11] G. Calderon-Salmeron, F. Schwack, P. Joshi, and S. Glavatskih, "A reliability case study of the impact of tribology on wind turbine gearboxes," *Research Square*, Jan. 2023, doi: [10.21203/rs.3.rs-2507649/v1](https://doi.org/10.21203/rs.3.rs-2507649/v1).
- [12] B. A. Lobo, Ö. S. Özçakmak, H. A. Madsen, A. P. Schaffarczyk, M. Breuer, and N. N. Sørensen, "On the laminar-turbulent transition mechanism on megawatt wind turbine blades operating in atmospheric flow," *Wind Energy Science*, vol. 8, no. 3, pp. 303–326, Mar. 2023, doi: [10.5194/wes-8-303-2023](https://doi.org/10.5194/wes-8-303-2023).
- [13] R. Damiani, D. Davis, and B. Summerville, "Aeroelastic modeling for distributed wind turbines: March 11, 2021 - November 10, 2021," Sep. 2022, doi: [10.2172/1888764](https://doi.org/10.2172/1888764).
- [14] C. N. Aslanov and K. C. Jafarov, *Wind turbine*, Patent F2023 0031, Intellectual Property Agency of the Republic of Azerbaijan, 2023.
- [15] J. N. Aslanov, A. B. Sultanova, Z. S. Huseynli, and F. F. Mustafayev, "Determination of radial strains in sealing elements with rubber matrix based on fuzzy sets," in *Proc. 11th Int. Conf. Theory and Application of Soft Computing, Computing with Words and Perceptions and Artificial Intelligence (ICSCCW)*, 2022, pp. 1456.
- [16] "NREL: Dynamic Maps, GIS Data, and Analysis Tools - Wind Maps," *NREL.gov*, Sep. 3, 2013. [Online]. Available: <https://www.nrel.gov/gis/wind.html>.
- [17] *Appendix II: IEC Classification of Wind Turbines, Wind Resource Assessment and Micrositing, Science and Engineering*, pp. 269–270, 2015.